

# Gauge Valve

目次 (ページ)

## User's Manual



1. Be sure to read the following warranty clauses of our product .....	1
2. General operating instructions .....	2
3. General instructions for transportation, unpacking and storage .....	2
4. Name of parts .....	3
5. Working pressure vs. temperature .....	4
6. Installation procedure .....	5
7. Operating procedure .....	6
8. Disassembling method for replacing parts .....	7
9. Inspection items .....	7
10. Troubleshooting .....	8
11. Handling of residual and waste materials .....	8





This user's guide contains very important information for the proper installation, maintenance and safe use of an ASAHI AV Product.

Please store this manual in an easily accessible location.

### <Warning & Caution Signs>

 Warning	This symbol reminds the user to take caution due to the potential for serious injury or death.
 Caution	This symbol reminds the user to take caution due to the potential for damage to the valve if used in such a manner.

### <Prohibited & Mandatory Action Signs>

	Prohibited: When operating the valve, this symbol indicates an action that should not be taken.
	Mandatory action: When operating the valve, this symbol indicates mandatory actions that must be adhered to.

## 1. Be sure to read the following warranty clauses of our product

- Always observe the specifications of and the precautions and instructions on using our product.
- We always strive to improve product quality and reliability, but cannot guarantee perfection. Therefore, should you intend to use this product with any equipment or machinery that may pose the risk of serious or even fatal injury, or property damage, ensure an appropriate safety design or take other measures with sufficient consideration given to possible problems. We shall assume no responsibility for any inconvenience stemming from any action on your part without our written consent in the form of specifications or other documented approval.
- The related technical documents, operation manuals, and other documentation prescribe precautions on selecting, constructing, installing, operating, maintaining, and servicing our products. For details, consult with our nearest distributor or agent.
- Our product warranty extends for one and a half years after the product is shipped from our factory or one year after the product is installed, whichever comes first. Any product abnormality that occurs during the warranty period or which is reported to us will be investigated immediately to identify its cause. Should our product be deemed defective, we shall assume the responsibility to repair or replace it free of charge.
- Any repair or replacement needed after the warranty period ends shall be charged to the customer.
- The warranty does not cover the following cases:
  - (1) Using our product under any condition not covered by our defined scope of warranty.
  - (2) Failure to observe our defined precautions or instructions regarding the construction, installation, handling, maintenance, or servicing of our product.
  - (3) Any inconvenience caused by any product other than ours.
  - (4) Remodeling or otherwise modifying our product by anyone other than us.
  - (5) Using any part of our product for anything other than the intended use of the product.
  - (6) Any abnormality that occurs due to a natural disaster, accident, or other incident not stemming from something inside our product.
- ※ Note that damage induced by a defect of our product is not covered by warranty.

## 2. General operating instructions



Warning

- Using a positive-pressure gas with our plastic piping may pose a dangerous condition due to the repellent force particular to compressible fluids even when the gas is under similar pressures used for liquids. Therefore, be sure to take the necessary safety precautions such as covering the piping with protective material. For inquiries, please contact us. For conducting a leak test on newly installed piping, be sure to check for leaks under water pressure. If absolutely necessary to use a gas in testing, please consult your nearest service station beforehand.



Caution

- Do not step on or apply excessive weight on valve. (It can be damaged.)
- Keep the valve away from excessive heat or fire. (It can be damaged, or destroyed.)



Caution

- Always operate the valve within the pressure vs. temperature range. (The valve can be damaged or deformed by operating beyond the allowable range.)
- Allow sufficient space for maintenance and inspection.
- Select a valve material that is compatible with the media. For chemical resistance information, refer to “CHEMICAL RESISTANCE ON ASAHI AV VALVE”.(Some chemicals may damage incompatible valve materials.)
- Do not use the valve in conditions where the fluid may have crystallized. (The valve will not operate properly.)
- Keep the valve out of direct sunlight, water and dust. Use cover to shield the valve.(The valve will not operate properly.)
- Perform periodic maintenance. (Leakage may develop due to temperature changes or over periods of prolonged storage, rest or operation.)

## 3. General instructions for transportation, unpacking and storage



Warning

- When suspending and supporting a valve, take care and do not stand under a suspended valve.



Caution

- This valve is not designed to handle impacts of any kind. Avoid throwing or dropping the valve.
- Avoid scratching the valve with any sharp object.
- Do not over-stack cardboard shipping boxes. Excessively stacked packages may collapse.
- Avoid contact with any coal tar creosote, insecticides, vermicides or paint. (These chemicals may cause damage to the valve.)
- When transporting a valve, do not carry it by the handle.



- Store products in their corrugated cardboard boxes. Avoid exposing products to direct sunlight, and store them indoors (at room temperature). Also avoid storing products in areas with excessive temperatures. (Corrugated cardboard packages become weaker as they become wet with water or other liquid. Take care in storage and handling.)
- After unpacking the products, check that they are defect-free and meet the specifications.

## 4. Name of parts

20mm (3/4")

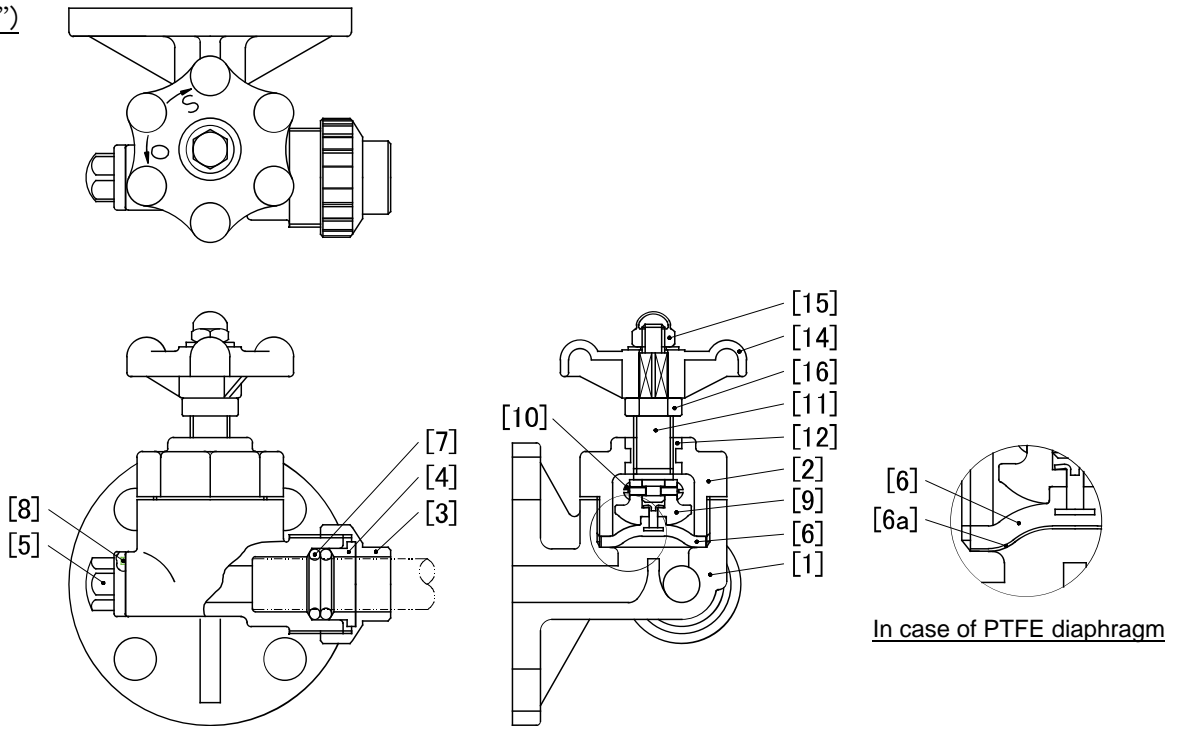

25mm (1")

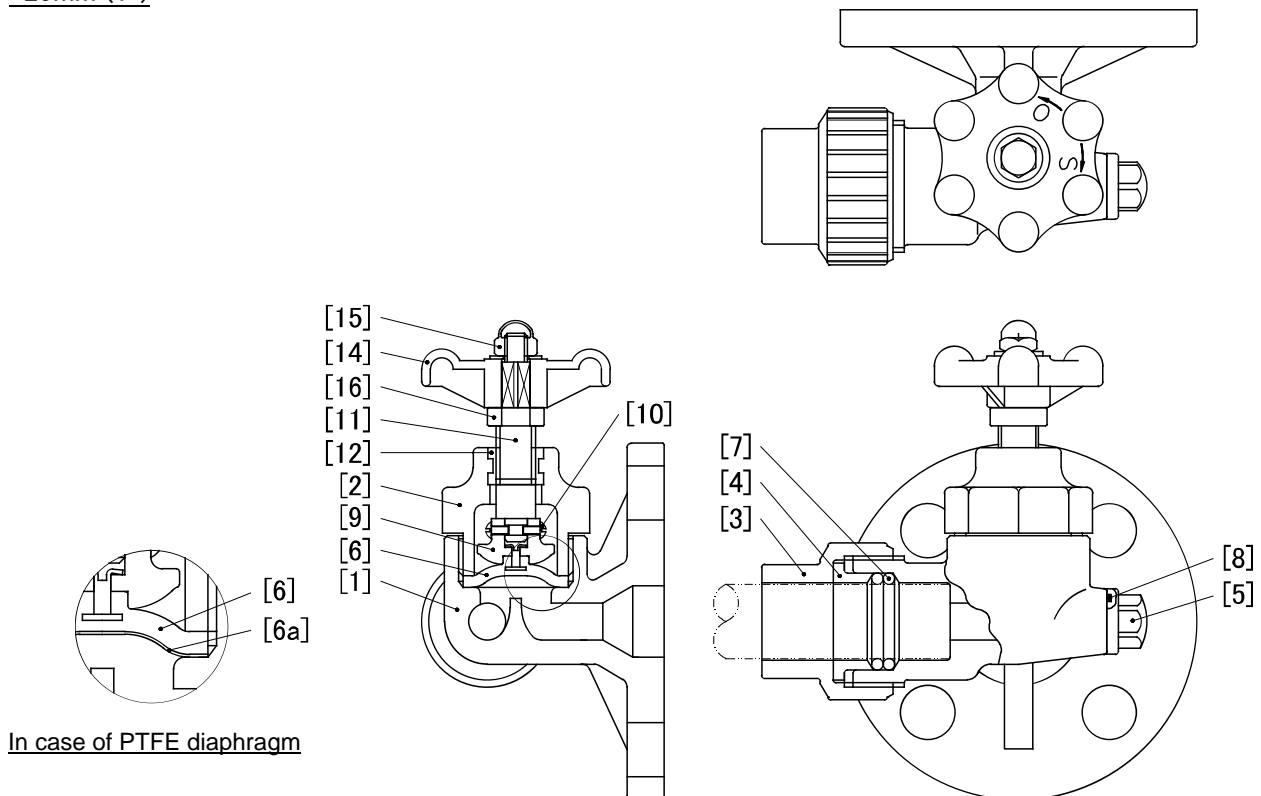

No.	Description	No.	Description	No.	Description	No.	Description
[1]	Body	[5]	Drain plug	[8]	O-ring (B)	[12]	Inserted metal
[2]	Bonnet	[6]	Rubber diaphragm	[9]	Compressor	[14]	Hand wheel
[3]	Gland nut	[6a]	PTFE diaphragm	[10]	Compressor pin	[15]	Nut
[4]	Gland	[7]	O-ring (A)	[11]	Stem	[16]	Stopper

Flanged elbow



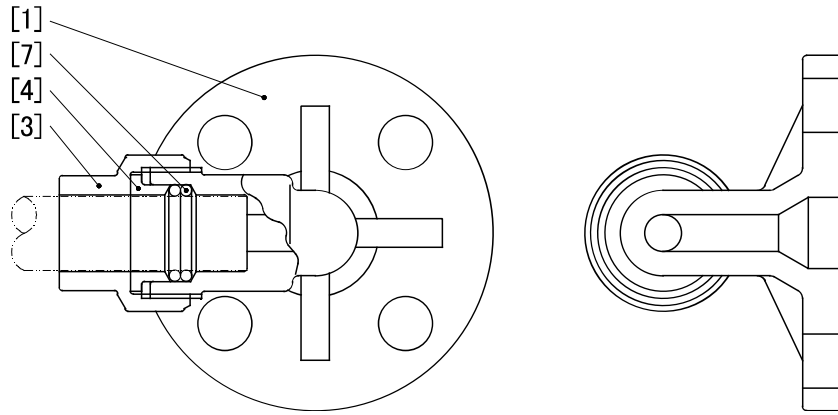

No.	Description
[1]	Body
[3]	Gland nut
[4]	Gland
[7]	O-ring (A)

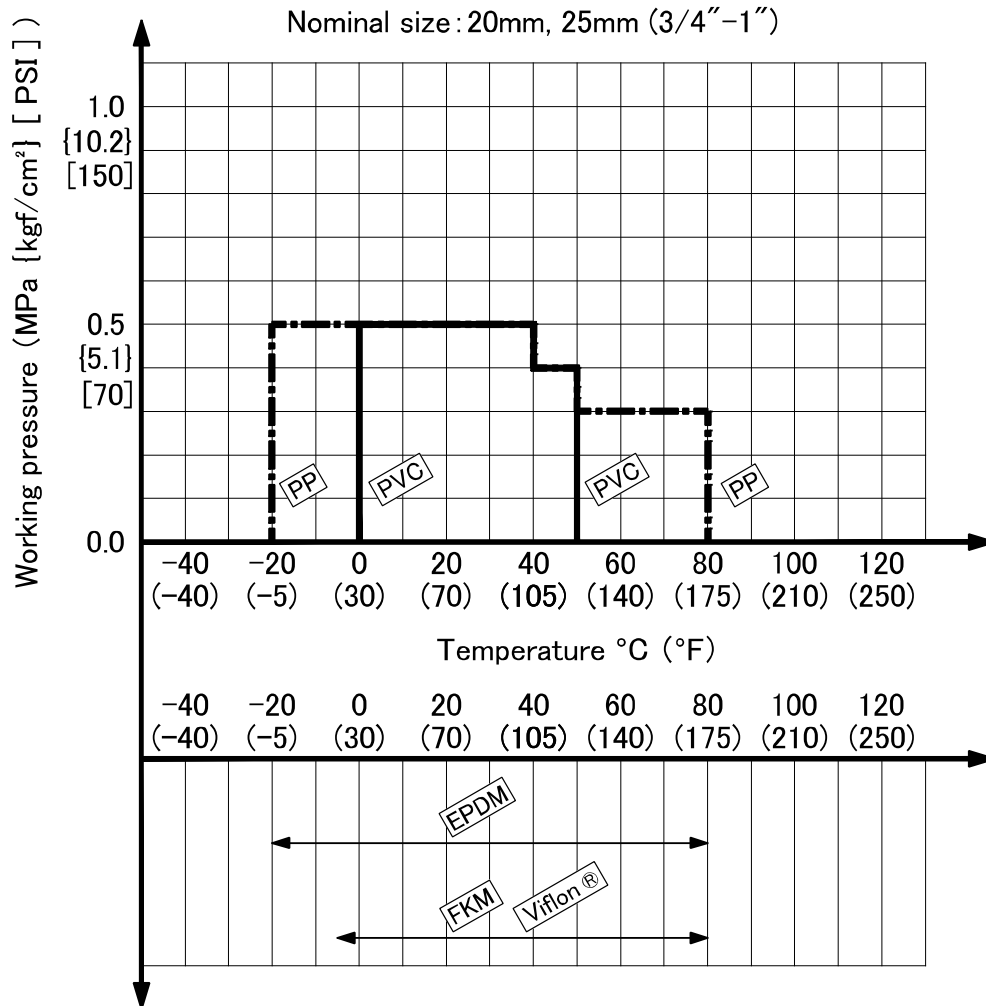



**5. Working pressure vs. temperature**



## 6. Installation procedure

- Warning**   – Be sure to conduct a safety check on all hand and power tools to be used before beginning work.
- Wear protective gloves and safety goggles as fluid remain in the valve even if the pipeline is empty. (You may be injured.)
- Caution**   – When installing a pipe support by means of a U-band or something similar, take care not to over-tighten. (Excessive force may damage the pipe.)
- When installing pipes and valves, ensure that they are not subjected to tension, compression, bending, impact, or other excessive stress.

### Flange part



- Caution**   – Use flat faced flanges for connection to AV Valves.
- Ensure that the mating flanges are of the same standards.
  - Be sure to use sealing gaskets (AV Gasket), bolts, nuts, and washers and tighten them to specified torques. (When a non-AV gasket is used, a different tightening torque instruction should be followed.)

### Necessary items

- Torque wrench
- Gauge pipe
- AV gasket

### Procedure



- 1) Set the AV gasket between the flanges.
- 2) Insert washers and bolts from the pipe side, insert washers and nuts from the valve side, then temporarily tighten by hand.

- Caution**   – The parallelism and axial misalignment of the flange surface should be under the values shown in the following table to prevent damage the valve. (A failure to observe them can cause destruction due to stress application to the pipe.)

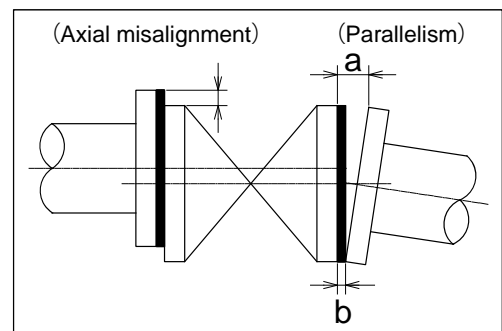
Nominal size	Axial misalignment	Parallelism (a-b)
20, 25mm (3/4", 1")	1.0mm (0.04 inch)	0.5mm (0.02 inch)



- 3) Tighten the bolts and nuts gradually with a torque wrench to the specified torque level in a diagonal manner.
- 4) Tighten it more than 2 turns clockwise with specified torque.

- Caution**   – Do not tighten above the specified torque value. (The valve can be damaged or leaks.)

### Specified torque value

Unit ; N-m [kgf-cm] [lb-inch]

Nominal size	20mm (3/4")	25mm (1")
PTFE coted / PVDF coted	17.5 [179] [155]	20.0 [204] [177]
Rubber	8.0 [82] [71]	20.0 [204] [177]

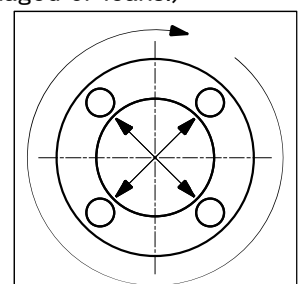

## Gauge pipe part

### Procedure

- 1) Loosen and remove the gland nut by hand, remove the gland and O-ring (A) from body.
- 2) Set the gland nut, gland, and O-ring (A) through the glass pipe to let through in advance.
- 3) Insert the glass pipe into the body, tighten the gland nut by hand and fix the gauge pipe.

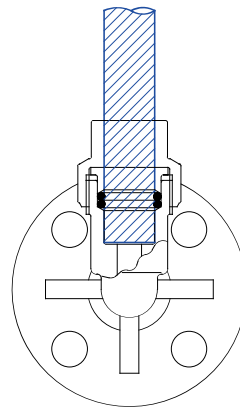
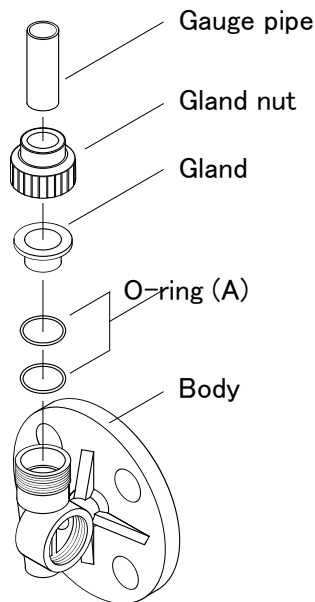

Gauge pipe insert completed drawing

Gauge pipe outside diameter

Nominal size	Outside diameter
20mm (3/4")	18mm (0.709 inch)
25mm (1")	26mm (1.024 inch)

## 7. Operating Procedure



Caution



– Do not open/close the valve when foreign matters such as dust are included in fluid.

– Foreign matters such as sand may be left inside the pipeline after the installation of the valve. Therefore, clean inside the pipe before opening/closing the valve.







– Do not exert excessive force in open/close the valve. (The hand wheel can be damaged.)

– When operating the hand wheel, be sure to do so with your hand. (Using a tool may damage the hand wheel.)

### Procedure

- 1) Turn the hand wheel to open and close. Turning it clockwise will close it, turning it counter-clockwise will open it.
- 2) Check the open and close state. When the valve shuts, operation torque of the valve is high.

## 8. Disassembling method for replacing parts

-   – Wear protective gloves and safety goggles as fluid remain in the valve even if the pipeline is empty. (You may be injured.)
-   – Be sure to conduct a safety check on all hand and power tools to be used before beginning work.
-   – Take care not to over-tighten the gland nut. (The valve can be damaged.)
-  – Do not use the pipe wrench. (The valve can be damaged.)

### Necessary items

- Torque wrench
- Safety goggles
- Spanner wrench
- Monkey wrench
- Protective gloves
- Phillips head screwdriver

### <Disassemble>

#### Procedure



- 1) Completely discharge fluid from pipeline.
- 2) Loosen the valve side gland nut, and remove the gauge pipe.
- 3) Loosen and remove the pipeline bolt and nut by spanner wrench, and the remove the body part from pipeline.
- 4) Loosen and remove the nut on the hand wheel.
- 5) Remove the hand wheel.
- 6) Loosen and remove the bonnet by monkey wrench.
- 7) Remove the stem from the bonnet.
- 8) Loosen and remove the compressor pin attached to compressor by phillips head screwdriver.
- 9) Remove the compressor from the stem.

### <Assembly>

#### Procedure

- 1) Assembly by using reverse procedures on assembly steps 1) to 9).
- 2) Confirm that manual operation can be performed smoothly after assembly.

## 9. Inspection items

-   – Perform periodic maintenance. (Leakage may develop due to temperature changes or over periods of prolonged storage, rest or operation.)

#### ○ Inspect the follow items

(1)	Existence of scratches, cracks, deformation, and discoloring.
(2)	Existence of leakage from the valve to the outside.
(3)	Bonnet loose or not.
(4)	Gland nut loose or not.
(5)	Hand wheel operation a smoothly or not.



**10. Troubleshooting**

Problem	Cause	Treatment
Fluid leaks from the body and the bonnet.	The bonnet is loose.	Retighten the bonnet.
	Media has crystallized.	Disassemble and cleaning.
Fluid leaks from the valve even when the valve is closed fully.	Solid particles have lodged.	Disassemble and cleaning.
	Valve body weir or diaphragm is scratched.	Replace the parts.
Fluid leaks from the gland nut and the gauge pipe.	Grand nut is loosen.	Retighten the gland nut.
	Solid particles have lodged.	Disassemble and cleaning.
	O-ring is worn or damaged.	Replace the O-ring.
	Gauge pipe is damaged.	Replace the gauge pipe.
Fluid leaks from stem part.	Diaphragm is breaks or worn.	Replace the diaphragm.

**11. Handling of residual and waste materials**

 - Make sure to consult a waste treatment dealer for recommendations on the proper disposal of plastic valves. (Poisonous gas is generated when the valve is burned improperly.)

Gauge Valve**ASAHI YUKIZAI CORPORATION**

Distributor

<http://www.asahi-vukizai.co.jp/>